



## Tire & Rubber Industry

Complete solutions  
Machine components

# Contents

---

System solutions for the tire industry	4
Calender upstream and downstream	6
Bias cutter for textile and steel cord	7
Extrusion line downstream	8
Assembly line	10
Customized assembly line	11
EL.TAG: RFID machine	12
EL.TAG: Unique solution designed to improve your business	13
Weight-watching machine	14
Rewinding machine	16
Liner with an endless life	17
Cleaning machine	18
Rewinding and cleaning machine: 2 processes in 1 unique solution	19
Rewinding machine for different cassette sizes	20
Rewinding machine for cassettes and bobbings	21
Let-offs and wind-ups for laminator line	22
Set of let-offs and conveyors for TBR	22
Questionnaire	23

## CUSTOMIZED SOLUTIONS FOR THE TIRE AND RUBBER INDUSTRY



FOCUS ON CUSTOMER SATISFACTION

---

INTELLIGENT TECHNOLOGY · SMART PRODUCTS

---

INTERNATIONAL LOCATIONS · WORLDWIDE AVAILABILITY

---

# CUTTING-EDGE TECHNOLOGY AT HOME ALL OVER THE WORLD

## Erhardt+Leimer

### Global solutions for production of the future

Intelligent technologies and products in the highest quality designed to optimize the production processes of our customers all around the world. This is our claim as the internationally expanding Erhardt+Leimer group of companies.

With our global presence – from development to production and on to service – we are always close to the customer. We develop customer-specific solutions and provide our customers with excellent products either in digital or intelligent versions depending on their preference. Not only this, but we also set new standards for the production of tomorrow. In the process, it is not just our products that are increasingly becoming smart – our entire company is currently undergoing a digital transformation. One visible indication of this is the E+L online shop, which enables our customers to order products and spare parts quickly and easily from our website.

With more than 1,600 employees at sites across Europe, Asia, and America we deliver cutting-edge technology on-time to any location in the world.

In everything we do, we aim to use all company resources responsibly to protect the environment and demonstrate our commitment to increased sustainability.



## System solutions for the tire industry

Erhardt+Leimer Italy stands for worldwide competence in the development, assembly, installation, sales, and servicing of machines, processing lines, and integrated systems for different branches of industry and is therefore an essential pillar for the entire group of companies.

With the production of the first camera-based weft straightener for the textile industry in 2000, E+L Italy revolutionized its role within the group. In recent years, we have also evolved into a competent supplier of complete lines for the tire industry.

E+L Italy started operations on the Italian market in 1977 from a location in Florence. Initially the subsidiary focused only on sales and service for web guiding systems for the textile, paper, and plastics industries.

Since the start of the 1990s the company has been based in Bergamo, from where it looks after customers all around the world. The plant in Stezzano was expanded in 2015 to prepare for future growth.

From simple tasks to complex challenges, we offer customized solutions for clients in a variety of industries

- Textile
- Paper
- **Tire & Rubber**
- Non-Woven
- Corrugated cardboard
- Film
- Battery

At our production facilities in Italy, we assemble and thoroughly test every project to ensure the highest quality standards. From there, we deliver worldwide and support our customers throughout the installation process.

Do you have a specific concept or technical requirement? Contact us – our team will analyze your needs and develop a tailored solution that fits perfectly.



**Competence  
in engineering  
across the entire  
group of companies**





# CUSTOMIZATION

## **CUSTOMIZED SOLUTIONS**

We optimize your production  
with practical engineering solutions  
based on your company needs.

Your requirements are our motivation to deliver the perfect solution.

# Calender upstream and downstream

E+L manufactures different customized equipment for upgrade of the existing textile, steel, inner liner and conveyor belt calender lines.

### Applications

- Tire & Rubber
- Conveyor belt heavy duty
- PVC

### Layout

- Double let-off or shuttle let-off
- Splice press
- Different types of pulling units according to different positions along the line
- Hydraulic accumulator for pre and post calender application
- Pre-heating (steam or hot water) and cooling (chilled water) tower drums
- Over tension compensator
- Swivelling feeding conveyor for calender
- Bleeder cord applicator
- Pricking unit
- Cross cutter
- Wind-up: shuttle, dual, dual shuttle or tandem

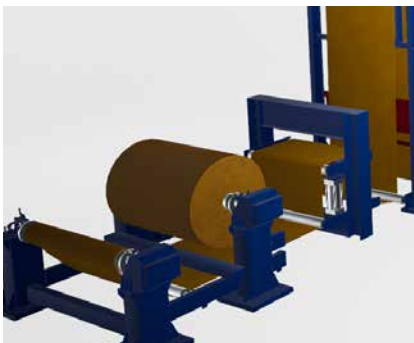
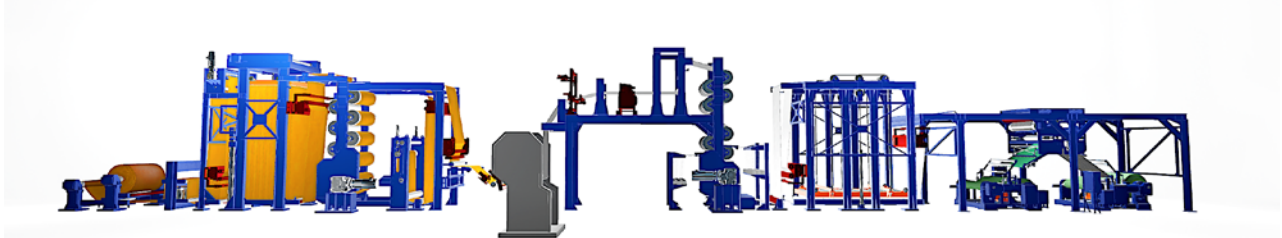

Let-off station

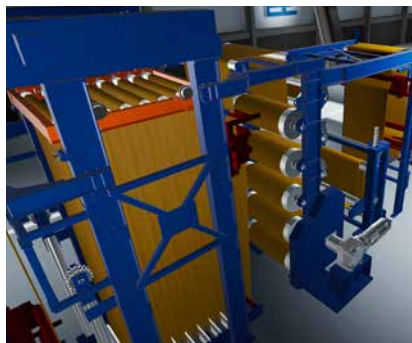

Accumulator and heating tower



CordAliner BCB31

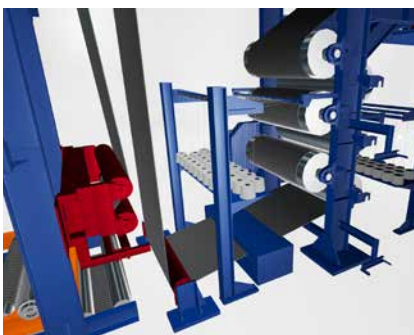

Bleeder and cooling tower



Dual wind-up with cutting system for automatic bobbins' change



EL-THICKNESS C-Frame NDS2

### Technical Data

Material	Textile cord, steel and textile cord rubberized, fabric for conveyor belt production	
Web width	450 mm to 1,860 mm	
Web tension	Pre calender	2,500 N
	Calender	20,000 N
	Post calender	5,000 N
Web speed	40 m/min to 100 m/min	
Thickness range	Before calender	0.4 mm to 4 mm
	After calender	0.6 mm to 10 mm

# Bias cutter for textile and steel cord

E+L offers the world-leading range of bias cutters (steel cord and fabric/textile cord cutting) for all kinds of tires: designed to cut material from the calender from low to orthogonal angle.

Customized execution for highest bias cutter line performance thanks to individually configurable machine layouts.

According to material dimensions and required productivity the splice is manual or automatic. A set of E+L devices controls position, tension and shape of the processed material.

The wide range of options (quality-related features, automation and quality control systems) ensures that every line can be customized according to the customers' needs.

## Applications

- Two/three wheelers, velo
- Passenger car and suv
- Light truck, truck and bus
- OTR
- Agriculture and industry
- Racing, Formula 1
- Aircraft
- Conveyor belts
- Special requirements made from steel or textile cord material

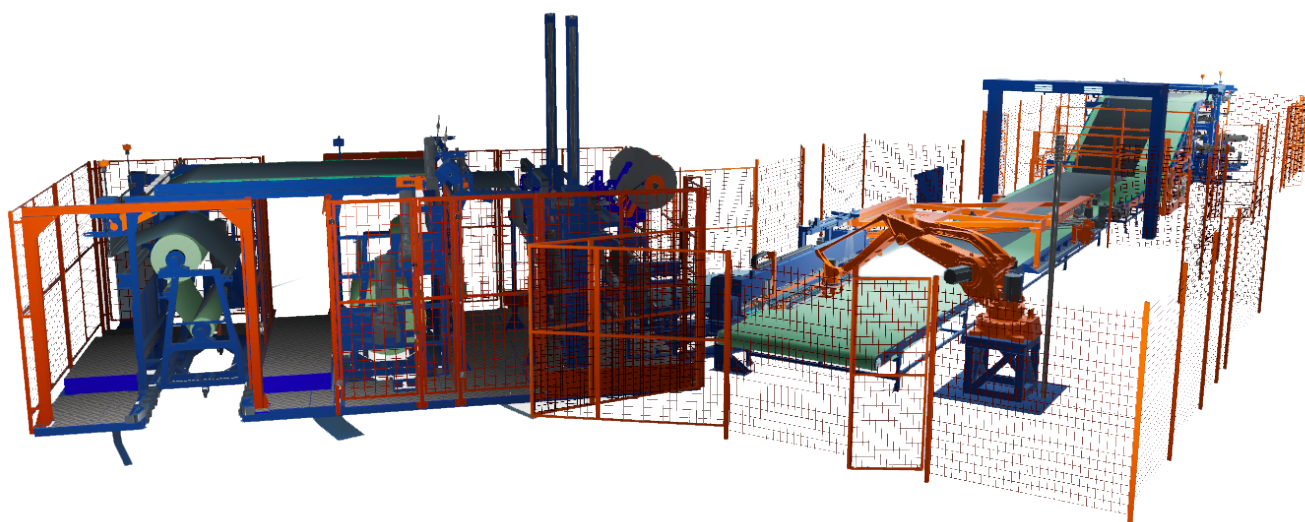

## Choose the recipe: we cut from high to low angles

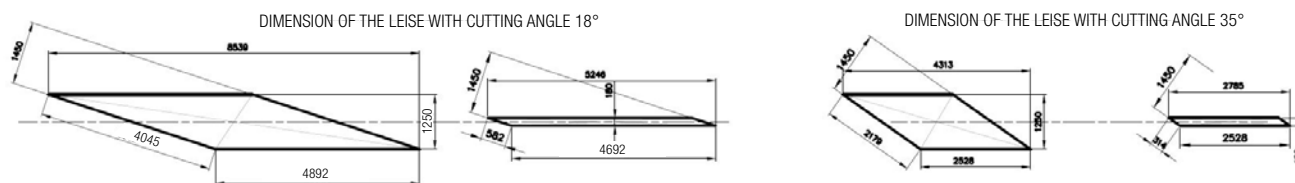

Examples of configuration and possible cutting angles

Technical Data	
Material	Textile and steel cord rubberized
Web width	Input width: 1,000 mm to 1,600 mm      Output width: 180 mm to 2,200 mm
Web speed	5 m/min to 30 m/min
Thickness range	0.4 mm to 2.0 mm
Cord angle	15° to 100°

# Extrusion line downstream

E+L manufactures different customized equipment for upgrade of the existing extrusion line.

The extruded product determines the downstream assembly equipment; this could be thread, sidewall or inner liner.

### Function

This equipment is intended

- to cool down the material coming from an extruder by means of water cooling inside a tunnel equipped with spraying nozzles
- to measure and monitor the quality parameters with respect to recipe parameters (width, weight, profile, temperature)

- to remove the water from the material surface by means of a blow-off system with air blades
- to wind up the cooled and dried material in bobbins

While the machine is running, the process parameters are measured and shared with the extruder's upstream to adjust the speed and to control the tension.

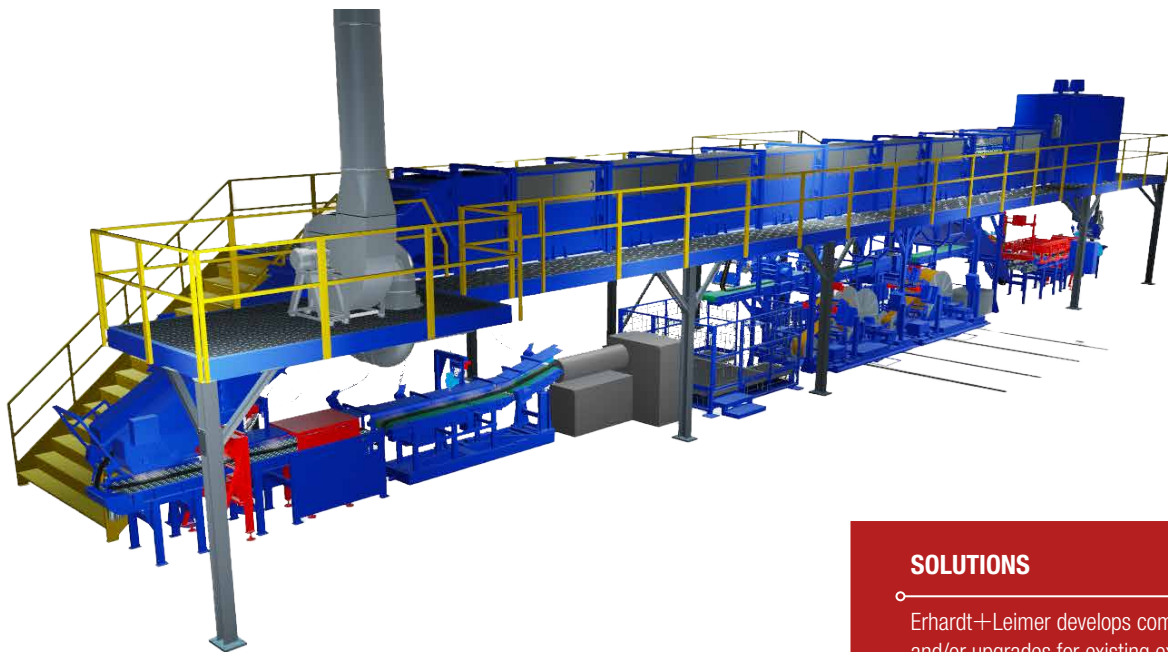

Extrusion line configuration with two floors

### SOLUTIONS

Erhardt+Leimer develops complete solutions and/or upgrades for existing extrusion lines

### Layout

- Take-off
- Camera OL 82 Width measuring system
- Thermo camera
- ELWEIGHT Weight measuring system
- EL-TRISCAN LS Online profile measuring system
- Fumes exhaust system
- Ascending/descending/transfer conveyors
- Cooling tunnel
- Water blow-off roller train
- Conveyors with metal detector and thermo camera
- EL-TRISCAN LS Online profile measuring system
- EL-PAPS Ink bottle positioning
- Color line inspection RS16
- Cross cutting unit
- Double wind-up station

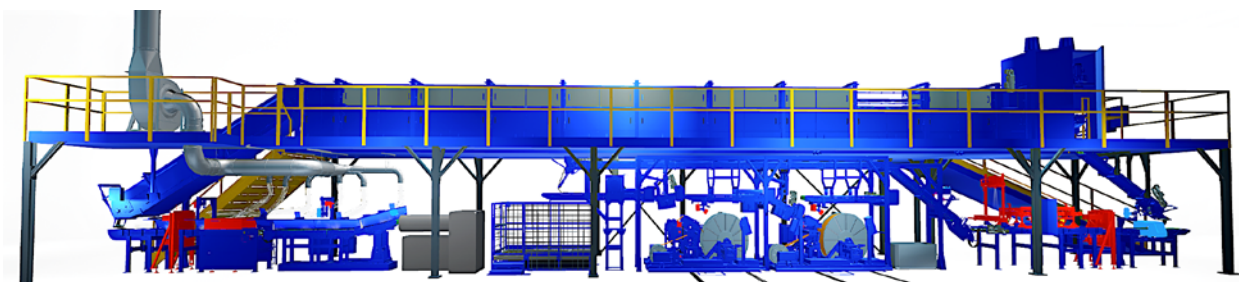

Extrusion line configuration with two floors

Suitable for tread, sidewall, rim and inner liner reinforcement applications:

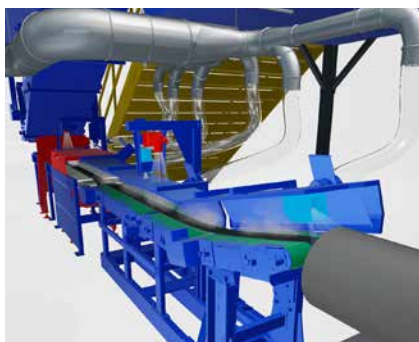

Take-off conveyor with OL 82 camera (width measuring system) and thermo camera

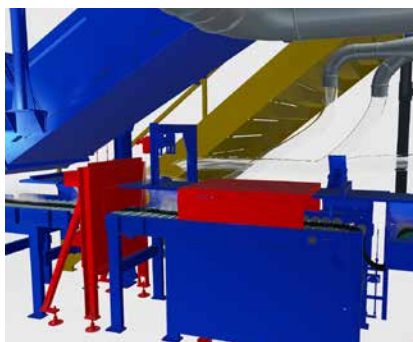

EL-WEIGHT (weight measuring system) and EL-TRISCAN LS (online profile measuring system)

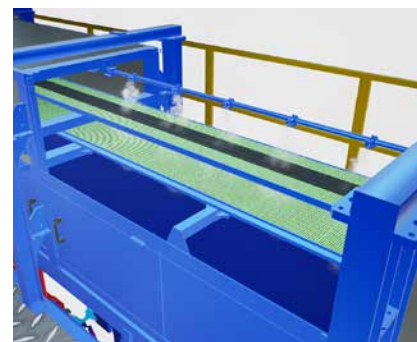

Water cooling tunnel



Water blow-off conveyor



EL-PAPS (ink bottle positioning) and Color line inspection RSi6



Double wind-up station



Ink bottle positioning EL-PAPS – NPS10

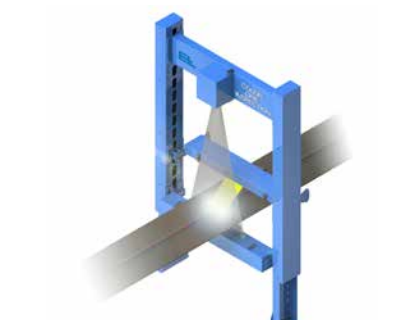

Color line inspection RSi6



Online profile measuring system EL-TRISCAN LS | Light section NLS10

Technical Data

Material	Multi compound rubber
Web width	20 mm to 600 mm
Web speed	5 m/min to 65 m/min
Thickness range	0.8 mm to 10 mm

## Assembly line

Cold and warm assembly lines are designed to laminate different layers and strips materials of semi finishing material stored in cassettes or bobbins. They can be stand-alone or integrated in an extrusion line.

Slave strips come from let-off (bobbin or cassette) or from mini extruder, in perpendicular or inline of machine direction. Automatic or manual threading of material on an assembly conveyor which can be textile or modular plastic conveyor.

E+L cameras are used to read the position of the master material to better apply the slave strips. These cameras can guide the master material according to the nose and groove detection.

Erhardt+Leimer develops high-technology solutions that are fully integrated and meet customized requirement of each customer.

- Manual or full automatic threading
- Inspection system to check the lamination quality
- Data control with recipe management
- Reaching CP and CPK values of 1,33 (up to 1,67)
- The final check system can be supplied with E+L cameras (black on black) or with laser triangulation technology

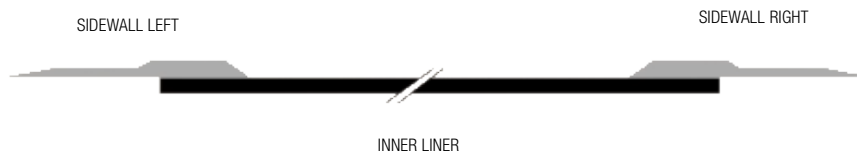

### Assembly line for positioning inner liner and rims/sidewalls

Assembly line for passenger material with automatic cutting unit to improve the production capacity



### Laminating station Complexer

- Highly accurate positioning by means of pre-positioning and final fine control
- Individually matched material infeed so that delicate rubber strips can be applied without mechanical stress
- Can be combined with cameras, laser triangulation and infrared sensors
- Integrated fieldbus interface for communication with the customer PLC
- Comprehensive control modes for highest requirements and accuracy
- Operation, service and diagnostic capability via web-based management or directly connected command station

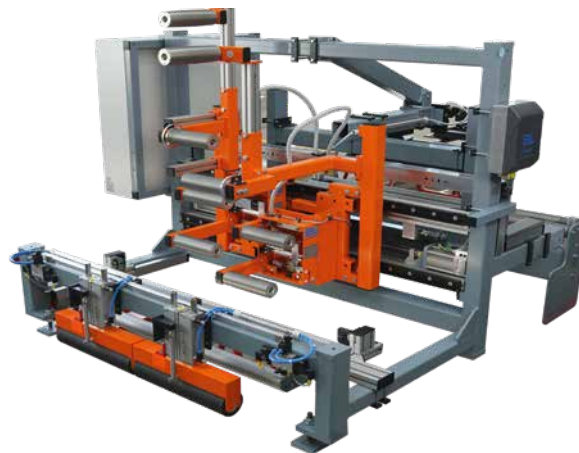

# Customized assembly line

## Doubling station chipper on sidewalls

Turning table able to wind and unwind following the material orientation

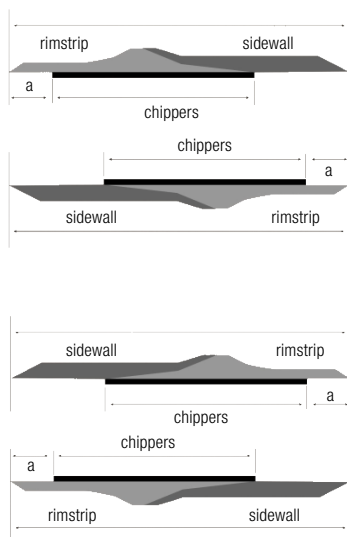

**HIGH QUALITY AND ACCURACY**

**TBM PRODUCTIVITY OPTIMIZATION**

**COST SAVING**

## Assembly line: four strips applicator

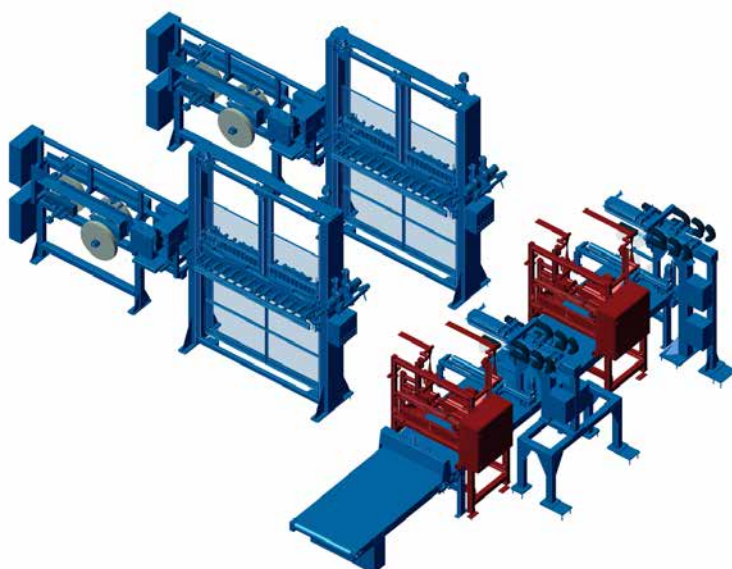

### Technical Data

Material	Multi compound rubber for tread / sidewall / inner liner / chafer
Web width	50 mm to 1,100 mm
Web speed	5 m/min to 40 m/min
Thickness range	0.5 mm to 4.0 mm

## EL.TAG: RFID machine

Erhardt+Leimer has developed a new machine for preassembling the RFID chip into a rubber patch.

Thanks to the RFID machine, our customers are provided with a finished product (RFID tag) composed of two rubber layers with the identification system inside.

### High-performance machine

- Only few seconds to assemble the RFID chip into two layers thanks to a robotic process
- Long-life ultrasonic gum strip cutter
- 2D camera system to monitor the robotic process
- Double quality control check: dimensional control by inspection system and functional control by direct reading system
- Identification system for the final bobbin (available on request)
- Scanner and labeller systems (available on request)

### CUTTING-EDGE TECHNOLOGY

Unique solution for high quality RFID tags



#### Technical Data

Typical strip application	60 mm x 10 mm x 0.6 mm*
Size accuracy	Very high and precise
Wind-up liner tension	<1 N
Tag position	Controlled
Single cycle time	Few seconds

\* Others on request

# EL.TAG: Unique solution designed to improve your business

## Gum strip let-off and blister unit

- Let-off unit to unwind customers' bobbins and gum strip foil removal.
- Blister unit composed of let-off, scrap unit with an automatic sliding knife, blister foil removal and foil wind-up.

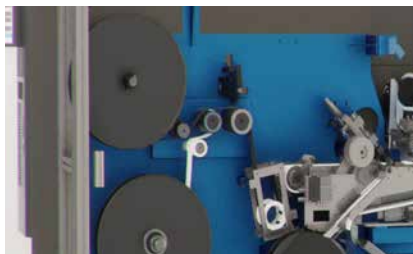

## Ultrasonic cutter

- Long life ultrasonic gum strip cutter continuously cuts the 1st strip and releases it on the assembly conveyor. While the RFID chip is picked, the conveyor moves a step forward and the 2nd strip is cut and picked.



## Double control check

- 2D Camera: input control made by a camera system to monitor the robotic process.
- 3D Camera: output inspection made by a camera system, able to check the correct dimension of the final tag and the correct position of the chip inside it.

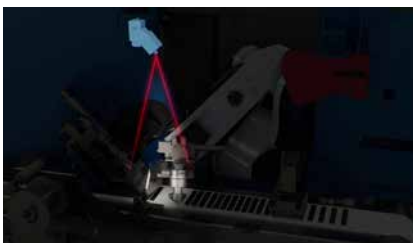

## RFID checker and transfer unit

- Output inspection in order to control the correct functionality of the RFID chip inside the tag.
- Pick and place system to transfer the RFID tag on a precise position of the plastic film. The plastic film is wound up on a final bobbin ready for the next production step.



**NEW**  
TECHNOLOGY  
FOR THE OTR  
INDUSTRY

## Weight-watching machine

Erhardt+Leimer has developed a new machine for inspecting tires of all sizes: thanks to this advanced technology customers can check both inside and outside in order to produce high quality tires.

### Structural features

- Heavy duty frame
- Weighing scale by load cells
- Lifting mechanism
- Forward and backward frame movement for an easier loading
- Clockwise and counter clockwise rotation
- Fixed position of the tire

### Quality inspection features

- Color camera system on the back side or inside the lifting to inspect the rear part and inner parts easily
- PC screens for an easier visualization of defects
- LED lights to improve the quality of inspection
- Additional hand held color camera for the inside surface extra inspection

### Electrical and software features

- Cabinet with air conditioning
- PC and wireless control systems
- Video recording of inspection
- Barcode scanner and tag identification
- ERP integration

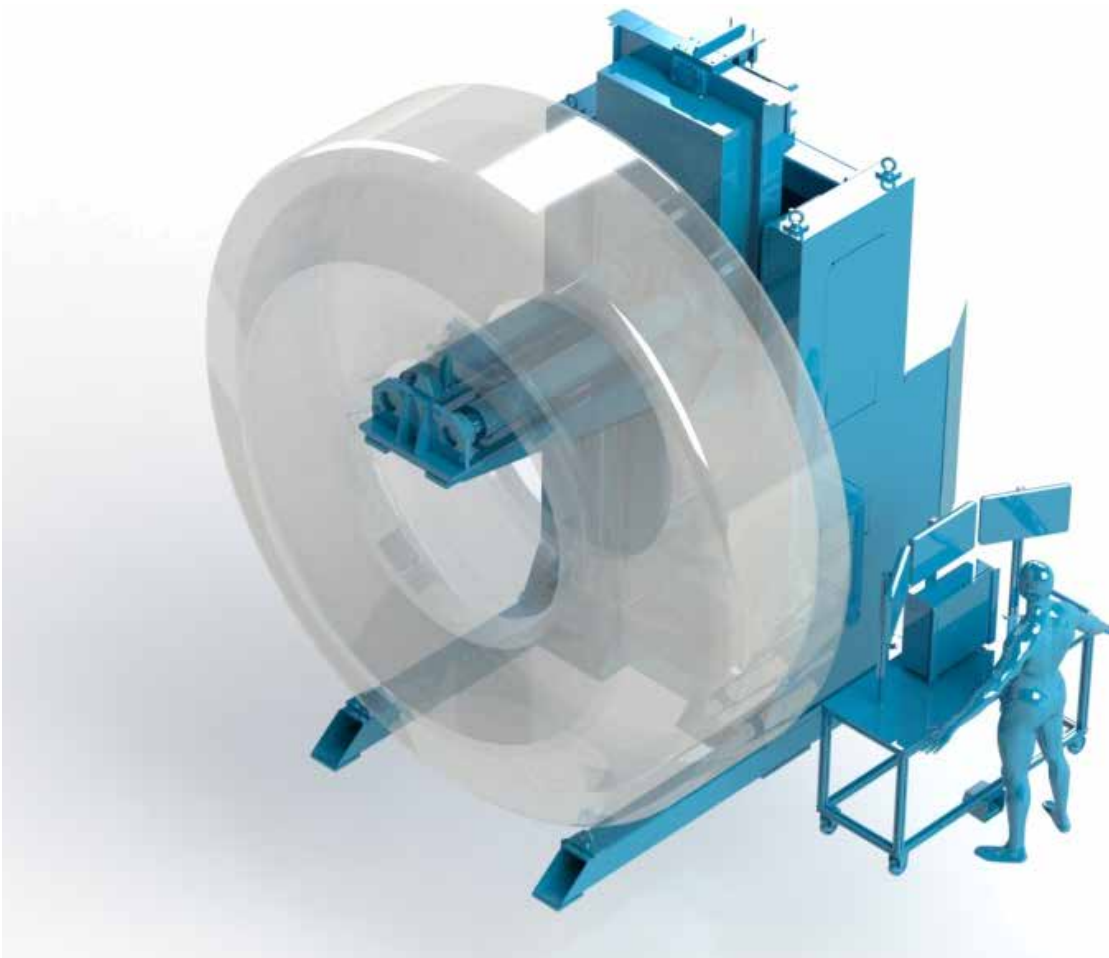

Tire weight-watching machine: fixed inspection part

**LIFETIME TIRE TRACKING**

**DEFECTS AND WEIGHT CONTROL**

**ERP INTEGRATION**

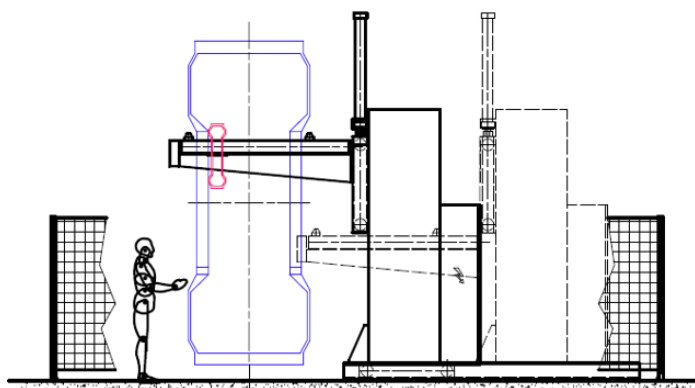

Big range inspection

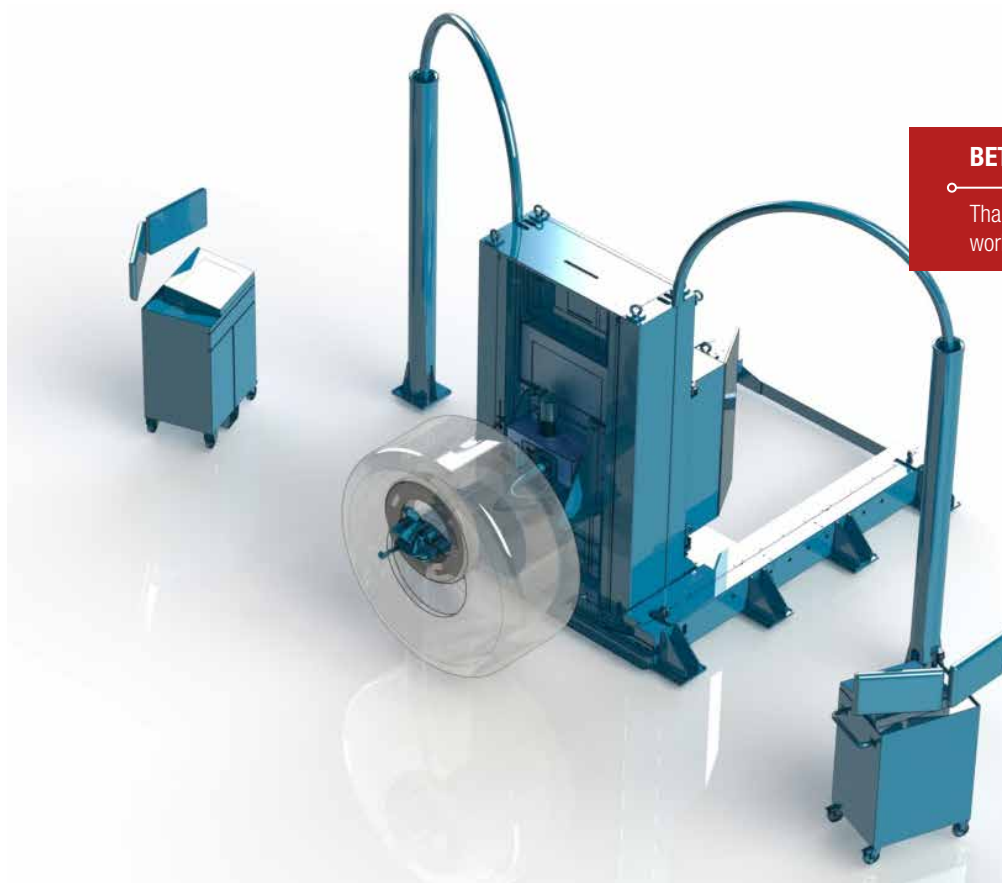
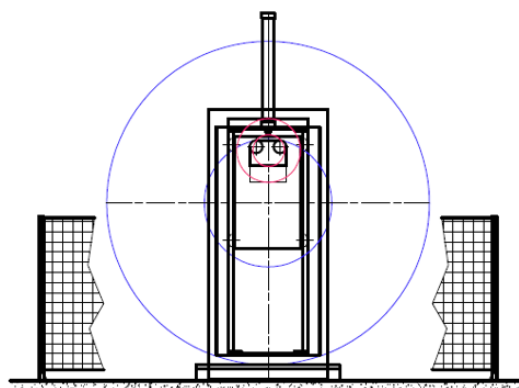

### BETTER AND SAFER

Thanks to our new technology the operators can work in better and safer workplace conditions

Tire weight-watching machine: movable inspection part

Technical Data	
Tire type	OTR, truck and bus
Tire types range	381 mm to 1,600 mm (15" to 63")
Tire sectional width	220 mm to 1,525 mm (9" to 60")
Tire O.D. diameter	800 mm to 4,050 mm (31" to 160")
Weight of the tire	24 kg to 7.0 t

## Rewinding machine

Rewinding machine to fix typical service liner problems in order to increase quality and productivity.

It is supplied with visualization of the damage and contamination. As an option, the customer can choose the automatic version.

### Layout

- Let-off with pneumatic core chucks driven by a geared motor
- Automatic sewing device
- Inspection table
- Wind-up
- ELTENS Load cells
- E+L Sensor
- EL.MOTION Actuating drive
- ELWINDER Winding station

### Rewinding machine detects and corrects the following problems

- Tear and hole presence
- Misalignment
- Defective edge
- Knot presence
- Fold presence

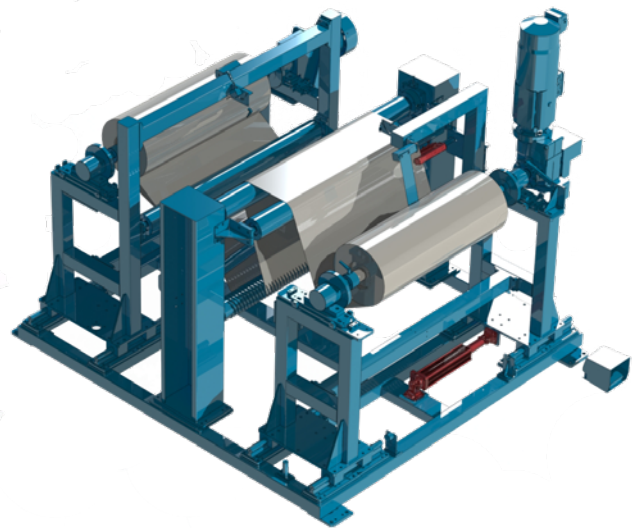

### MANY CONFIGURATIONS

Rewinding machines can be standard as shown in the main image or cantilever or multistation

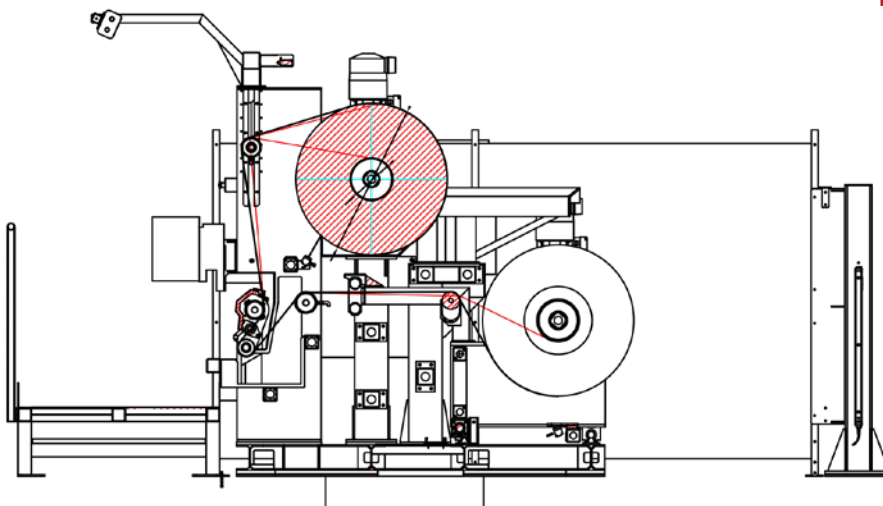

# Liner with an endless life

## Application

- Fabric liner (Cretonne)
- Polythene foil
- Polyester
- Plastic film
- Others

## Benefits

- Extended life of the liner
- Cost reduction in liner replacement
- Faster bobbins set up/changes
- Customized solutions based on customer needs and requirements

## Functions

- Guiding
- Spreading
- Repairing (cutting and sewing) by removing damaged parts
- Tension control
- Manual or automatic damage inspection

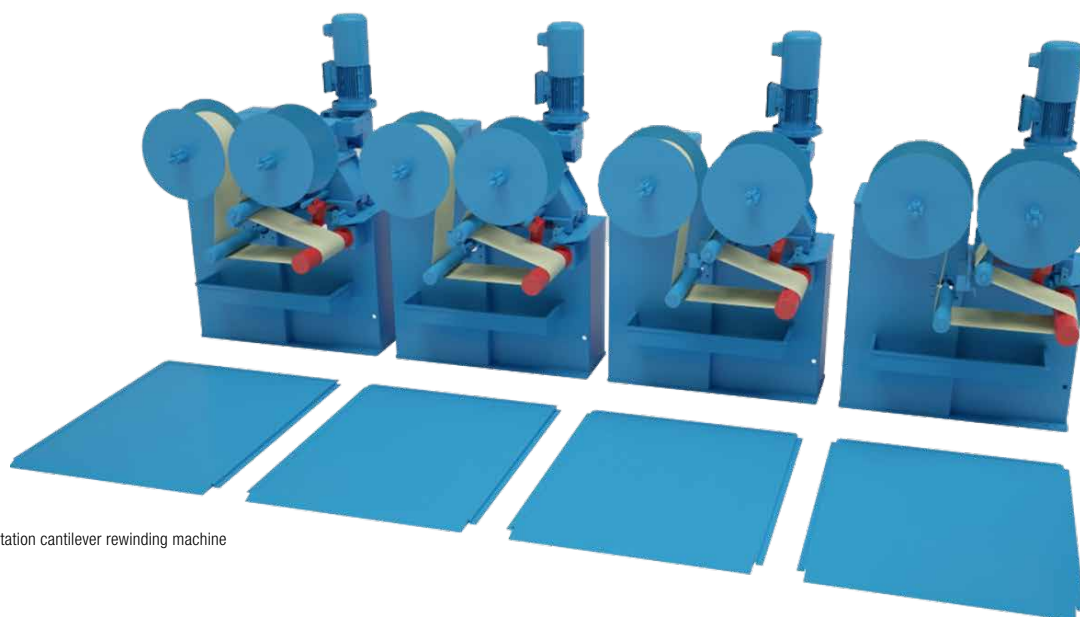

Multistation cantilever rewinding machine

Technical Data	
Material	Cretonne, polythene foil, polyester and plastic film
Web width	Cantilever: 50 mm to 700 mm      Double frame: 300 mm to 1,600 mm
Web speed	5 m/min to 200 m/min
Correction	±100 mm
Web tension control	50 N to 1,000 N

## Cleaning machine

The automatic cleaning system is designed for liner cleaning used on the calendar or extrusion lines to ensure uninterrupted production and high quality. A lot of different solutions are available to adapt the machine for each bobbin and cassette.

### Layout

- Inlet and outlet liner stock
- Automatic material threading
- Driven beating roller
- Driven brushes
- Adjustable air blade
- Each group is equipped with one suction system
- Automatic material run out detection
- Residual rubber monitoring and detection
- ELGUIDER Web guiding system
- Edge defect detection
- Liner material spreading
- ELTENS Tension control with automated run out knot sensor
- Automatic forward of unwind/rewind cores

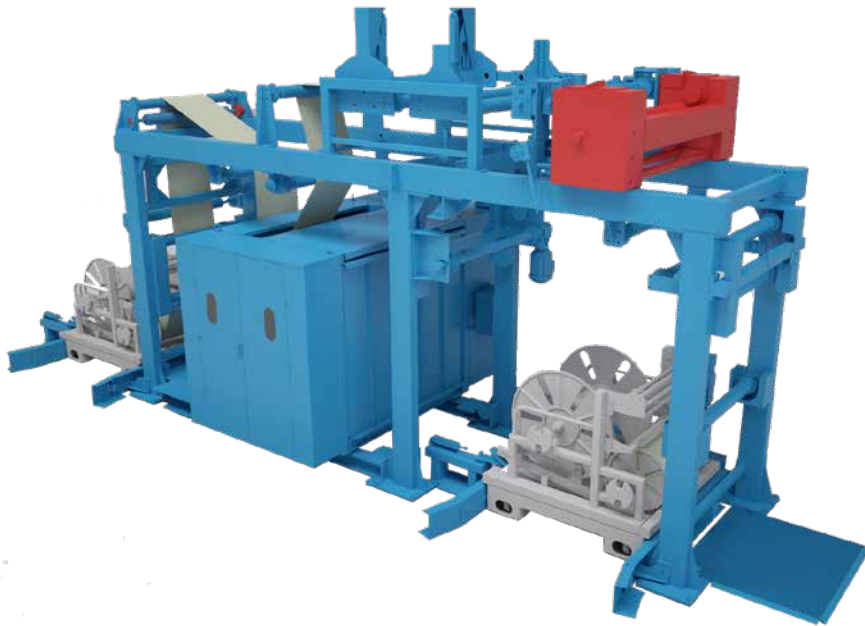

### ELCLEAN

- Modular machine which works with a mix of brushes, beaters and air blades in order to clean and remove the dust from the material
- Cleaning of both sides of the web simultaneously
- No distortion of the web
- Low operation and service costs

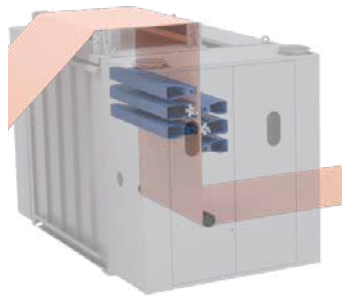

### Technical Data

Material	Liner: fabric, polythene foil, polyester and others material
Web width	100 mm to 1,800 mm
Web speed	Max. 200 m/min
Web tension	10 N to 300 N

# Rewinding and cleaning machine: 2 processes in 1 unique solution

## Application

- Fabric liner (Cretonne)
- Polythene foil
- Polyester
- Plastic film
- Others

## Benefits

- Extended life of liner
- Reduction in residual sulfur in order to improve the vulcanization process
- Reduction in liner replacement cost
- Detection of defects and contamination
- Improvement of the tire production quality

## Functions

- Guiding
- Cleaning
- Tension control

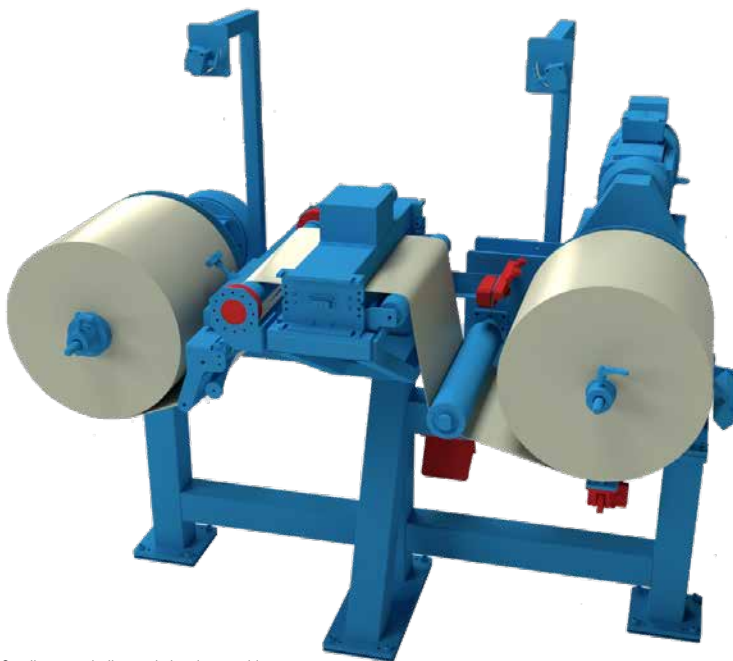

Cantilever rewinding and cleaning machine

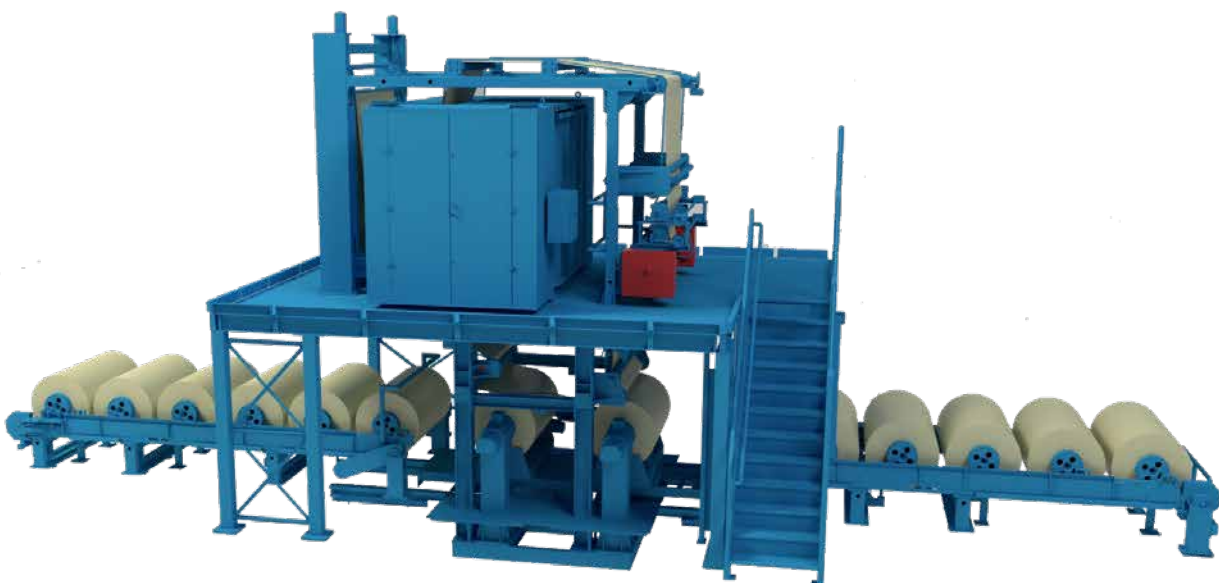

Automatic brushing machine

## Rewinding machine for different cassette sizes

### Application

- Adaptability to multi cassettes and multi-liner material (textile/polyester, polyethylene, etc.) used in tire-building machines
- This equipment is intended to restore the liner alignment throughout each wound from core to core
- Equipped with ELROLLER SRB: compact steering roller system with one or two rollers for different wrap angles and wear-free, brushless drive technology for highest positioning accuracy and control dynamics; integrated digital controller with position, speed, and current controller for highest quality positioning
- Integration of ELTENS load cells PD 21 because tension is a key factor for a correct liner conveying at each tire building process

### Scrap rubber removal function

- The scrap removal task can be: semi-automatic (via safety footswitch – light scrap) or automatic (from command station in a safe area – heavy scrap)

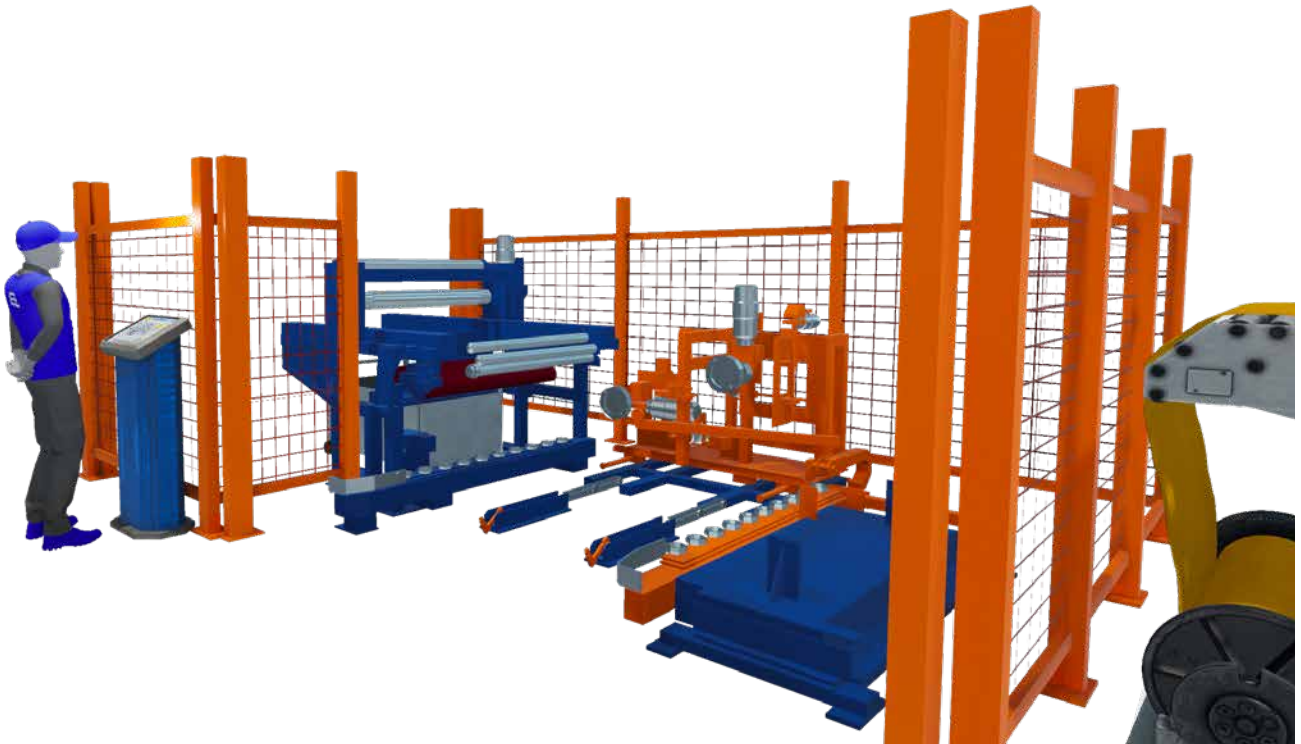

Polyethylene (rigid plastic)  
Polypropylene (soft plastic)  
1,150 mm



Textile  
Polyester/Cotton  
600 mm



Textile  
Polyester/Cotton  
450 mm



Polyethylene (rigid plastic)  
Polyurethane  
350 mm

# Rewinding machine for cassettes and bobbings

Offline station transfers inner liner, ply, steel belt and liner to different types of cassettes or bobbins. At the center belt conveyor the operator can also detect and remove the rubber defects. This customized machine is able to work in both running directions.

## Layout

- Let-off and wind-up for bobbin with liner guider
- Roller train conveyors
- ELSMART Segmented roller guider system
- E+L camera
- Transfer and inspection belt conveyor
- ELROLLER Steering roller system
- Wind-up and let-off with sliding frame for different types of cassettes

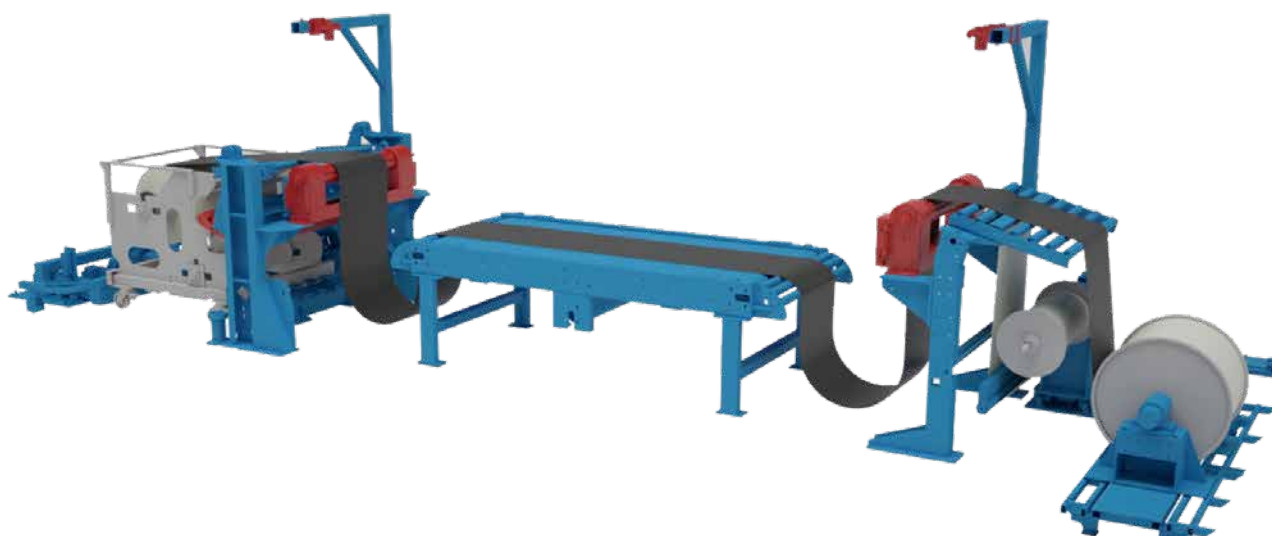

Steering roller system ELROLLER SRB43



Segmented roller guider system ELSMART SWB11

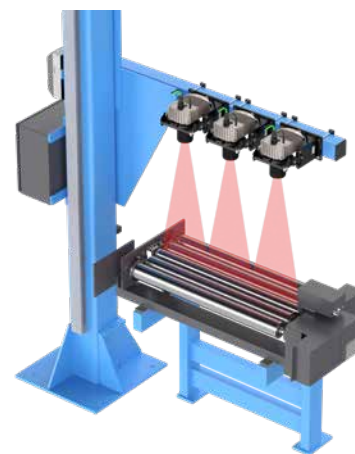

Hole and splice inspection system RSI3  
 CCD camera OL 91 (up to 3 units), OL 82 (up to 2 units)

## Let-offs and wind-ups for laminator line

This customized machine is capable to assemble up to eight layers of rubberized textile for conveyor belts.

### Scrap rubber removal function

- Unwinders
- Lamination units
- Length cutting unit
- Pulling unit
- Wind-up for final material
- Unwinders for liner

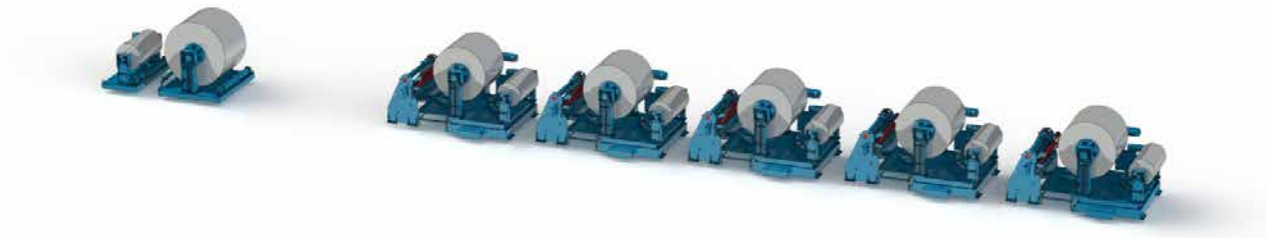

## Set of let-offs and conveyors for TBR

This customized machine is used to unwind and preguide up to five different materials and convey them in sequence to the tire building machine drum.

### Layout

- Unwinding stations laterally translating to permit loading/unloading
- Service liner rewinders integrated in unwinding stations
- SW systems to preguide the material
- Modular conveyors
- Movable front conveyor permitting to convey each material to building drum

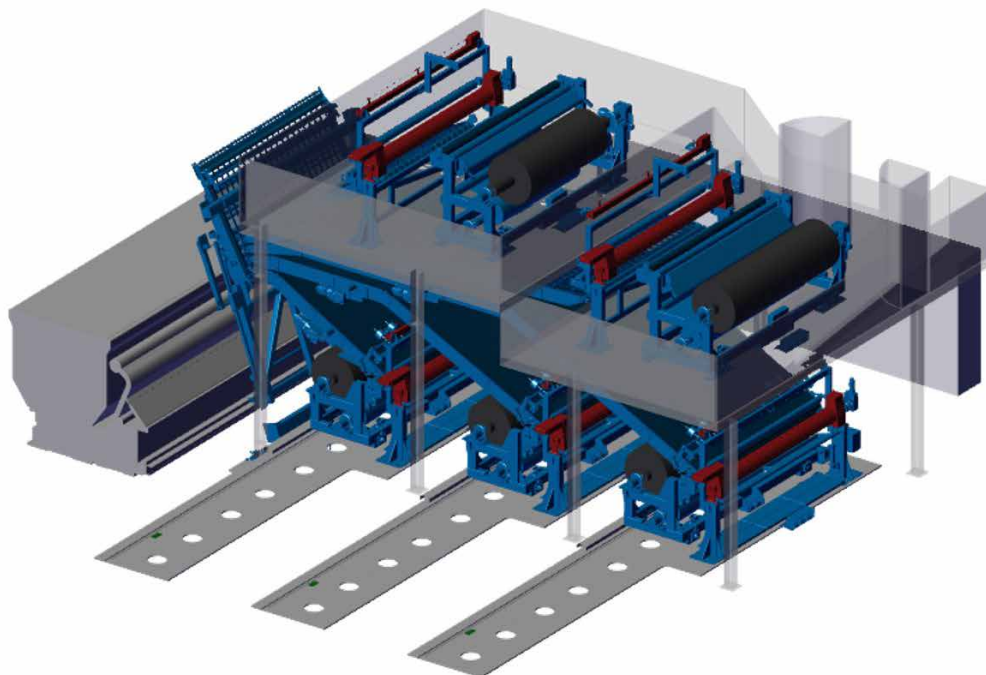

# Questionnaire

---

General data			
Customer			
Street			
Zip code		City/town	
Country		Internet	
Contact person			
Phone		E-Mail	
Project			

Technical data	
Type of machine	
Notes	

Comments

Date		Issuer	
------	--	--------	--

#### Head office

Erhardt+Leimer GmbH  
Albert-Leimer-Platz 1 · 86391 Stadtbergen, Germany  
Phone: +49 821/24 35-0  
info@erhardt-leimer.com · www.erhardt-leimer.com

#### Erhardt+Leimer Srl

Via Silvio Pellico 20/20A · 24040 Stezzano (BG) Italy  
Phone: +39 035 2050711  
commerciale@erhardt-leimer.com · www.erhardt-leimer.it

#### Subsidiaries

E+L Elektroanlagen Augsburg, Germany · E+L Steuerungstechnik St. Egidien, Germany  
E+L Bradford, England · E+L Mulhouse, France · E+L Stezzano, Italy · E+L Bucharest, Romania  
E+L Barcelona, Spain · E+L Burlington, Canada · E+L Duncan, S.C., USA · E+L Guarulhos-São Paulo, Brazil  
E+L Ahmedabad, India · E+L Hangzhou, China · E+L Tao Yuan, Province Taiwan · E+L Yokohama, Japan  
E+L Seoul, Republic Korea · E+L Bangkok, Thailand

Subject to technical modifications without notice · GRU--252091-EN-01 · 8/2025 · 930115

